

TOP OF COVER

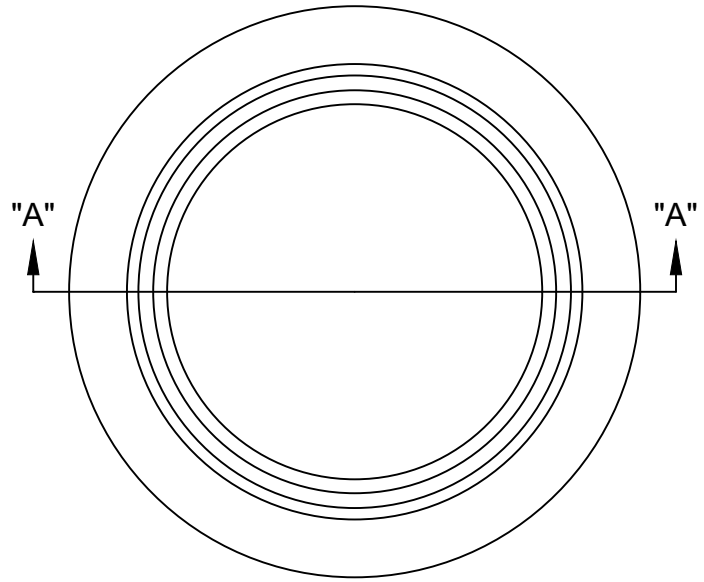

PLAN

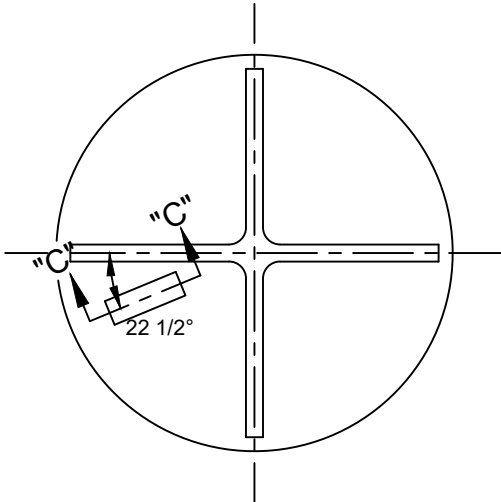

BOTTOM OF COVER

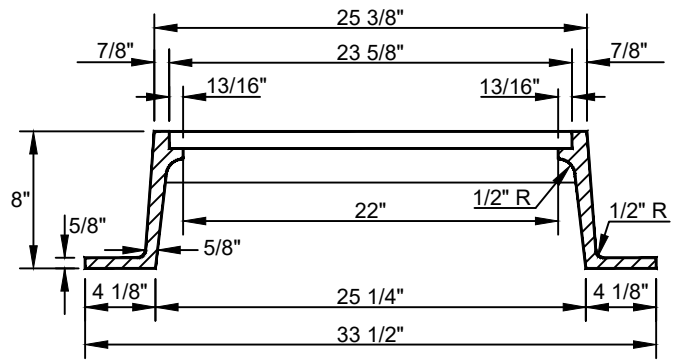

**SECTION "A"- "A"
MANHOLE FRAME**

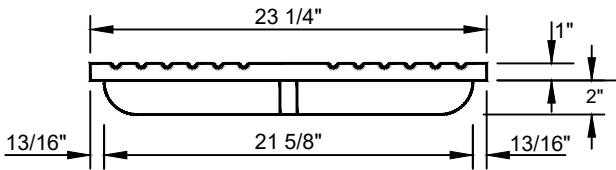

**SECTION "B"- "B"
MANHOLE COVER**

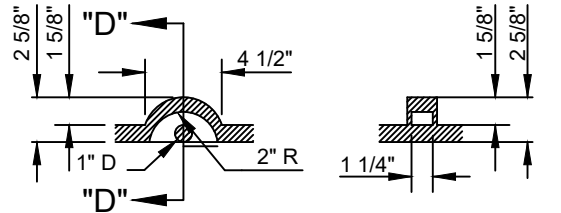

**SECTION "C"- "C" SECTION "D"- "D"
LIFTING EYE**

REVISION	BY	DATE	SANITARY SEWER MANHOLE FRAME AND COVER	
			STANDARD DETAILS	
			CITY OF JENKS OKLAHOMA	
			ENGINEERING DEPARTMENT	
			DATE: 4-11-22	STANDARD NO. SAN-07